

MONTAGGIO RACCORDO INGRESSO VERSIONE LATERALE

MONTAGGIO RACCORDO INGRESSO VERSIONE POSTERIORE



TABELLA PRESTAZIONI CONSUMI * (VALORI TEORICI)			
Apertura fessura doppia = 0.15 mm per lato fessura			
Pressione (Bar)	Consumo aria (NL/min)	Consumo aria (m ³ /h)	Forza di spinta misurata alla distanza di 200 mm (grammi)
1	213*	12.8*	90*
2	375*	22.5*	190*
3	528*	33.2*	300*
4	663*	31.8*	420*
5	762*	45.8*	532*
6	918*	54.8*	668*



simianproject.com

SCHEDA TECNICA PRODOTTO

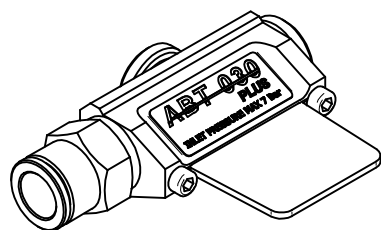
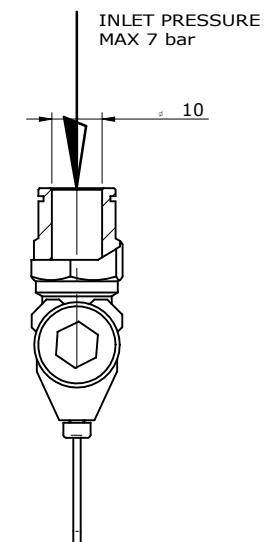
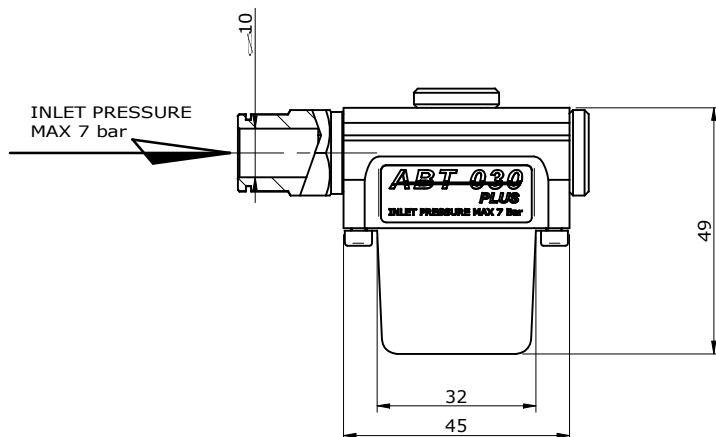
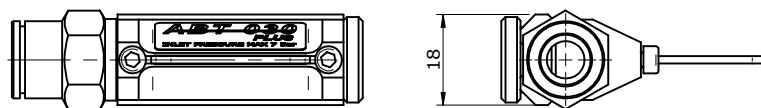
LAMA D'ARIA PLUS L=30 mm

DATA/DATE
03/01/2017

AUTORE/AUTHOR
L.Lombardi

PESO/WEIGHT
0.000 kg

CODICE/CODE
90ABT030 plus-S



SCALA/SCALE
1:1

REV.
00